

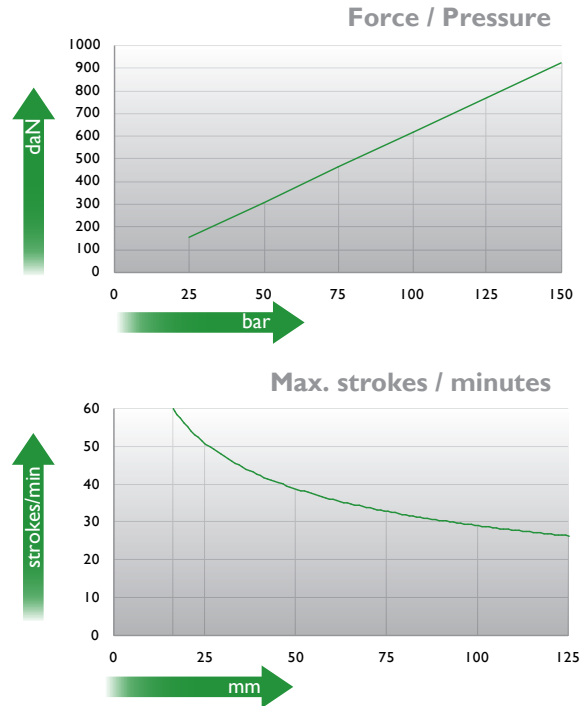

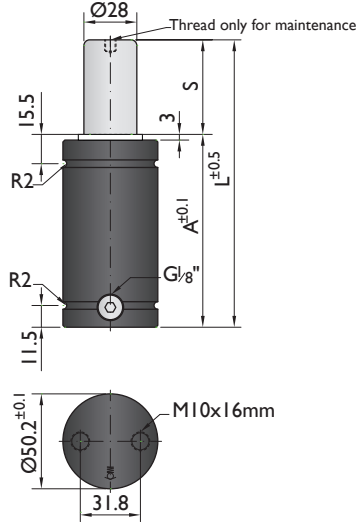

PSA
E24.54.815.G

SMS DNH
3203N



Ordering example: 4 x NT-1000-125

Order No.	S ⁽¹⁾ mm	L mm	A mm	F ₀ ⁽²⁾ daN	F daN	 ⁽³⁾	kg
				(20°C, 150 bar)			
NT-1000-13	13	78	65	920	1300	No	0.70
NT-1000-16	16	84	68		1300	No	0.76
NT-1000-19	19	90	71		1300	No	0.80
NT-1000-25	25	102	77		1300	No	0.84
NT-1000-32	32	116	84		1300	No	0.90
NT-1000-38	38	128	90		1400	No	0.96
NT-1000-50	50	152	102		1400	Yes	1.06
NT-1000-63	63	178	115		1400	Yes	1.18
NT-1000-75	75	202	127		1400	Yes	1.28
NT-1000-80	80	212	132		1400	Yes	1.35
NT-1000-100	100	252	152	1400	Yes	1.40	
NT-1000-125	125	302	177	1400	Yes	1.49	

⁽¹⁾ other strokes under request

⁽²⁾ alternative forces upon request

⁽³⁾ ESK available for other strokes



Pressure medium	N ₂	Working temperature	0-80°C	Min. security stroke	10%
Max. Charging pressure	150 bar	Temperature related force increase	+0.34%/°C	Repair Kit	KIT NT-1000
Min. Charging pressure	25 bar	Max. working speed	1.6 m/s	Linkable	G1/8"

Mounting possibilities

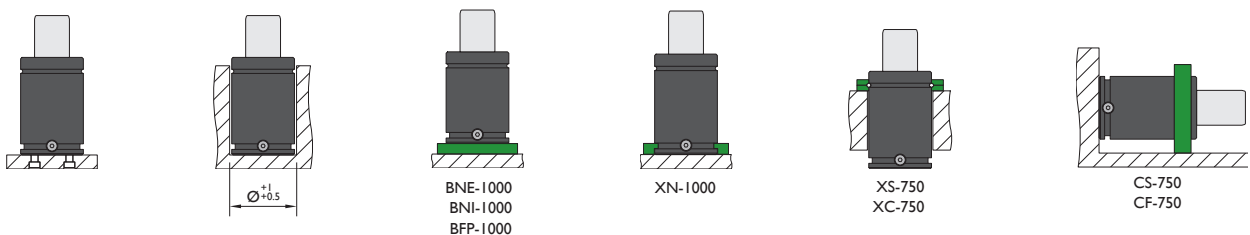

Flange must not support spring's force

Flanges

BNE-1000

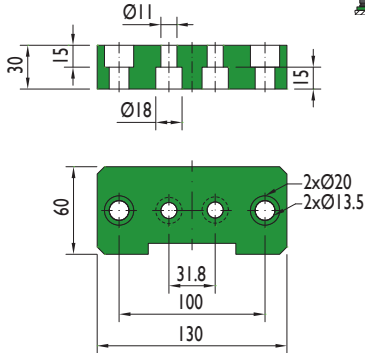

BNI-1000

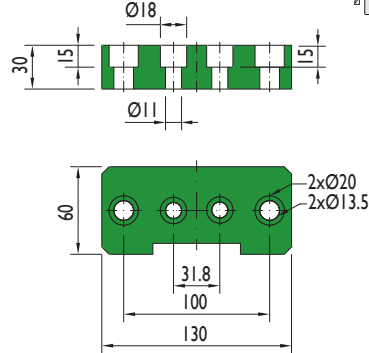

BFP-1000

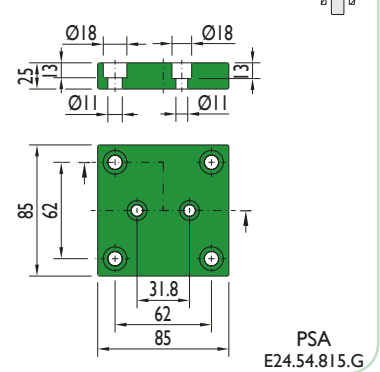

XN-1000

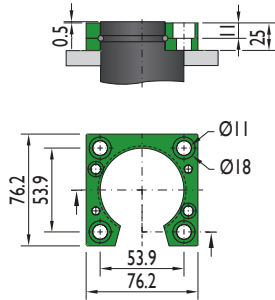

XS-750

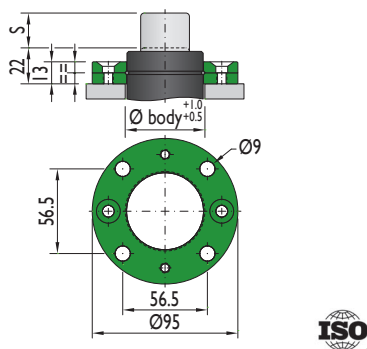

XC-750

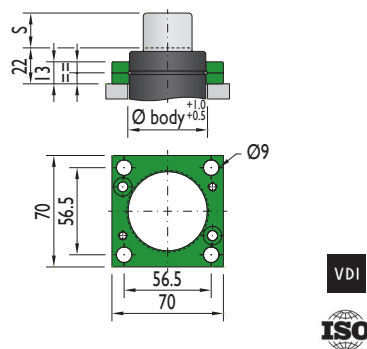

CS-750

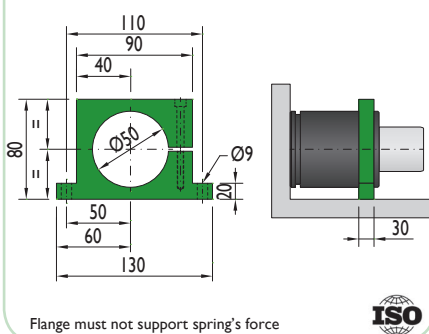

CF-750

