

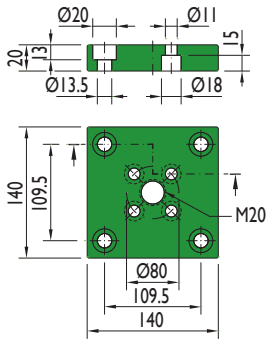

## Flanges

**BFE-5000**



**BFI-5000**

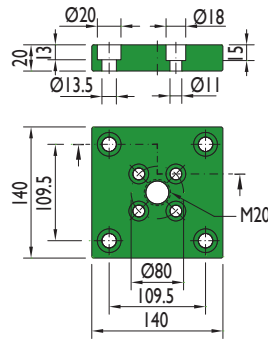

**MC-6500**

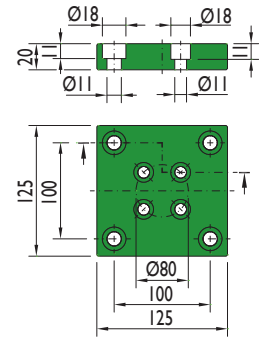

**GR-5000**

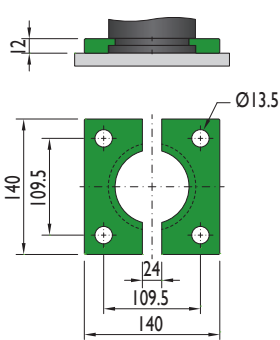

**MT-6500**

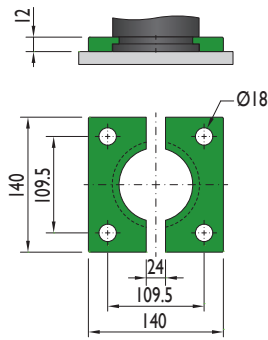

**AR-5000**

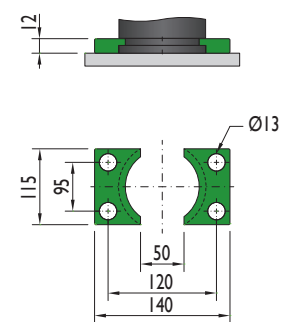

**XS-5000**

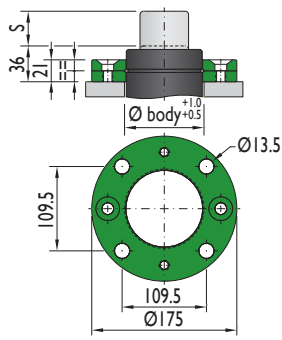

**XC-5000**

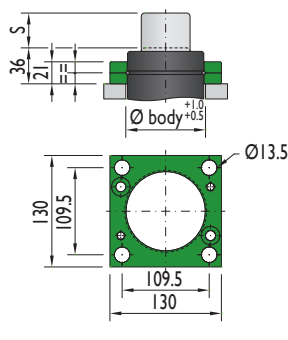

**PR-5000**

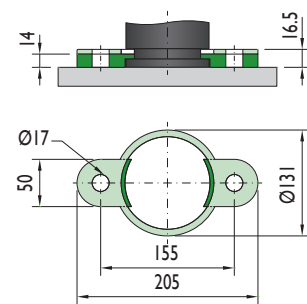

**CS-5000**

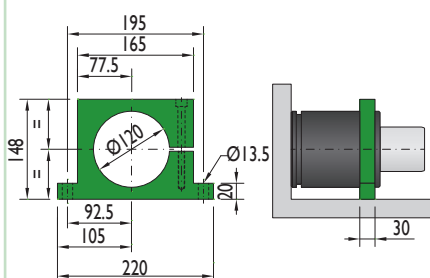

Flange must not support spring's force

**CF-5000**

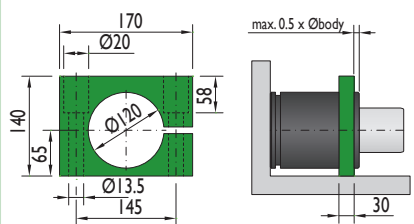

Flange must not support spring's force