

Ordering example: 4 x NT-6600-125

Order No.	S ⁽¹⁾ mm	L mm	A mm	F ₀ ⁽²⁾ daN (20°C, 150 bar)	F daN	 ⁽³⁾	kg
NT-6600-16	16	104	88	6600	8900	No	5.67
NT-6600-19	19	110	91		9100	No	5.81
NT-6600-25	25	122	97		9300	No	6.08
NT-6600-32	32	136	104		9600	No	6.41
NT-6600-38	38	148	110		9800	No	6.68
NT-6600-50	50	172	122		10000	No	7.21
NT-6600-63	63	198	135		10200	Yes	7.85
NT-6600-75	75	222	147		10300	Yes	7.31
NT-6600-80	80	232	152		10400	Yes	8.63
NT-6600-100	100	272	172		10500	Yes	9.56
NT-6600-125	125	322	197	10600	Yes	10.72	

⁽¹⁾ other strokes under request

⁽²⁾ alternative forces upon request

⁽³⁾ ESK available for other strokes



Pressure medium	N ₂	Working temperature	0-80°C	Min. security stroke	10%
Max. Charging pressure	150 bar	Temperature related force increase	+0.34%/°C	Repair Kit	KIT NT-6600
Min. Charging pressure	25 bar	Max. working speed	1.6 m/s	Linkable	G1/8"

Mounting possibilities

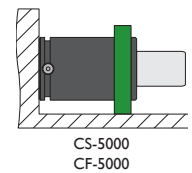
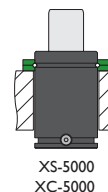
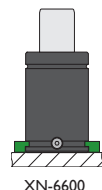
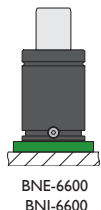
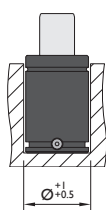
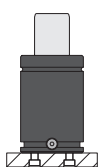

Flange must not support spring's force

Flanges

BNE-6600

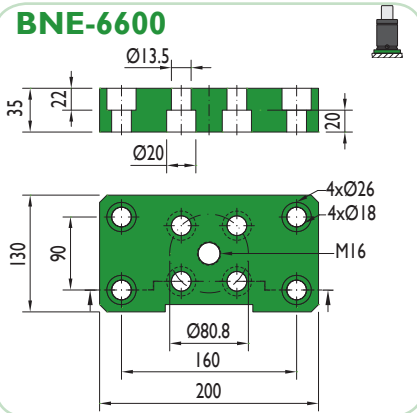

BNI-6600

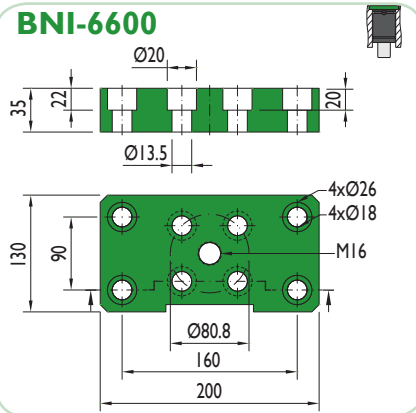

XN-6600

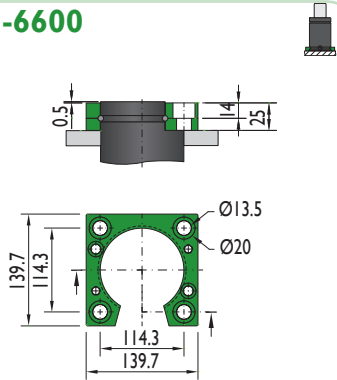

XS-5000

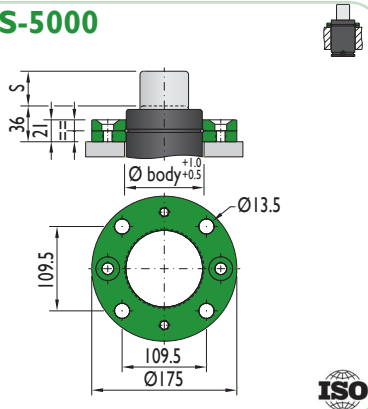

XC-5000

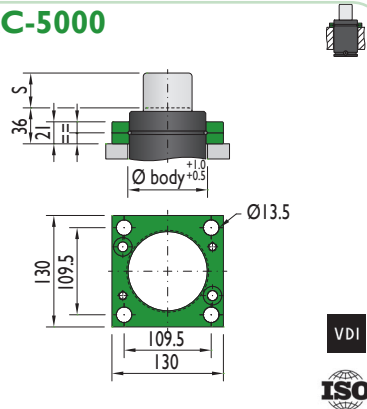

CS-5000

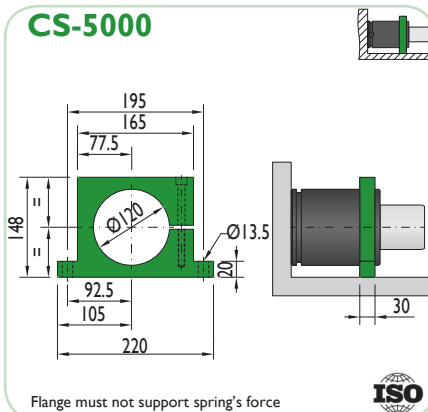

Flange must not support spring's force

CF-5000

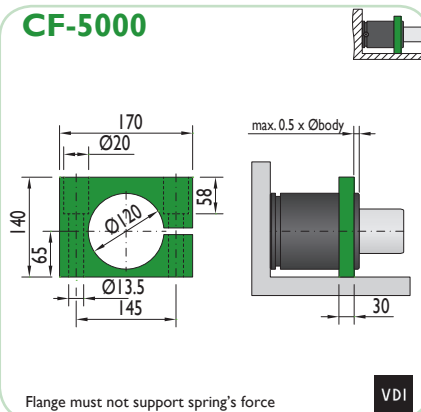

Flange must not support spring's force