

Ordering example: 4 x NT-9500-125

Order No.	S ⁽¹⁾ mm	L mm	A mm	F ₀ ⁽²⁾ daN (20°C, 150 bar)	F daN	 ⁽³⁾	kg
NT-9500-25	25	128	103		13200	No	11.60
NT-9500-32	32	142	110		13600	No	12.18
NT-9500-38	38	154	116		13800	No	12.67
NT-9500-50	50	178	128		14200	No	13.66
NT-9500-63	63	204	141	9500	17400	Yes	14.73
NT-9500-75	75	228	153		17300	Yes	15.72
NT-9500-80	80	238	158		17300	Yes	14.14
NT-9500-100	100	278	178		17200	Yes	17.78
NT-9500-125	125	328	203		17100	Yes	19.85

⁽¹⁾ other strokes under request

⁽²⁾ alternative forces upon request

⁽³⁾ ESK available for other strokes



Pressure medium	N ₂	Working temperature	0-80°C	Min. security stroke	10%
Max. Charging pressure	150 bar	Temperature related force increase	+0.34%/°C	Repair Kit	KIT NT-9500
Min. Charging pressure	25 bar	Max. working speed	1.6 m/s	Linkable	G1/8"

Mounting possibilities

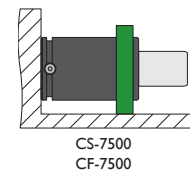
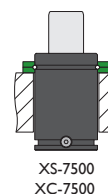
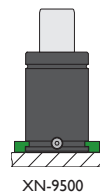
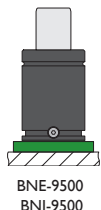
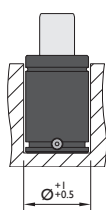
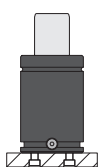

Flange must not support spring's force

Flanges

BNE-9500

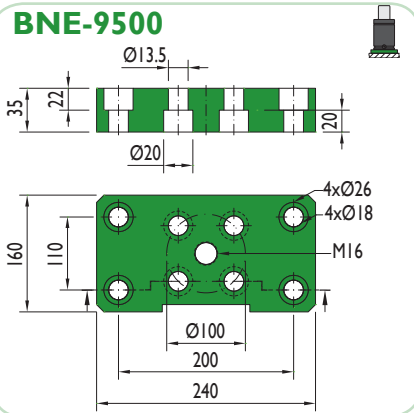

BNI-9500

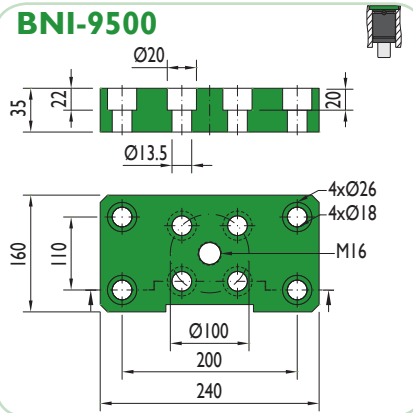

XN-9500

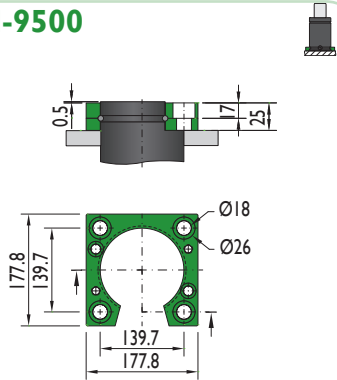

XS-7500

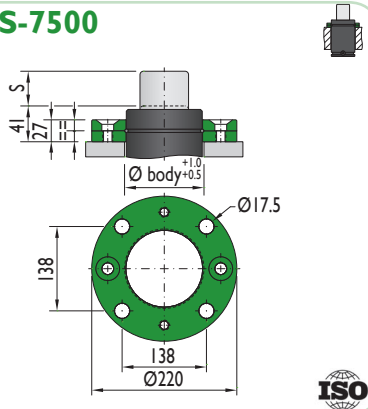

XC-7500

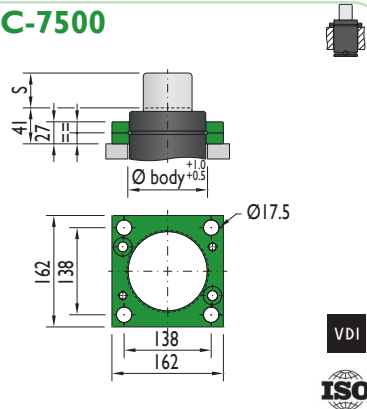

CS-7500

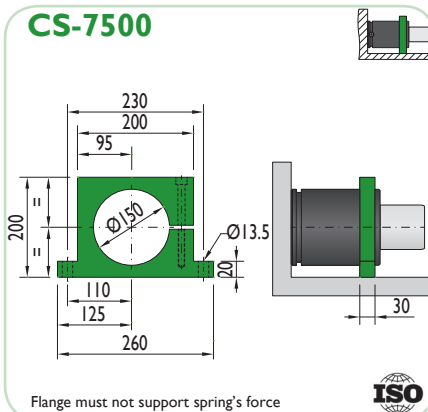

Flange must not support spring's force

CF-7500

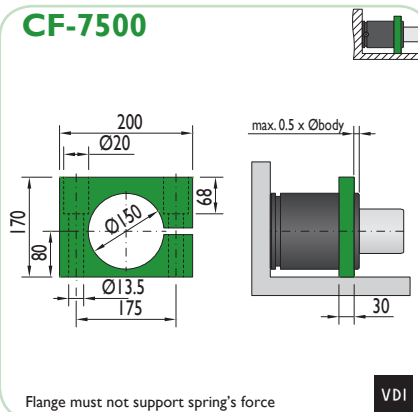

Flange must not support spring's force